

SDVH 3/2

S-VALVE HYDRAULIC DIVERSION VALVE – 130 BAR



PRODUCT FEATURES

- Designed for continuous use on high-rise or long-distance projects
- No movement of connected delivery lines
- Leak-proof S-Valve design with hydraulic switchover
- Selective charging of two delivery lines
- Shut-off option of one delivery line
- Withstands maximum delivery pressures with standard seals
- Can switch positions while under maximum pressure
- Standard ZX connections easily switch to HD or SK connections, no welding required
- External energy supply needed, e.g. BSA trailer pump; also operational with a manual hand press pump or any widely available hydraulic system
- All wear components and hydraulic cylinders are easily maintained.
- Lifting bracket for easy transportation
- CE-certified valve for worldwide availability

Additional diversion and gate valves available.

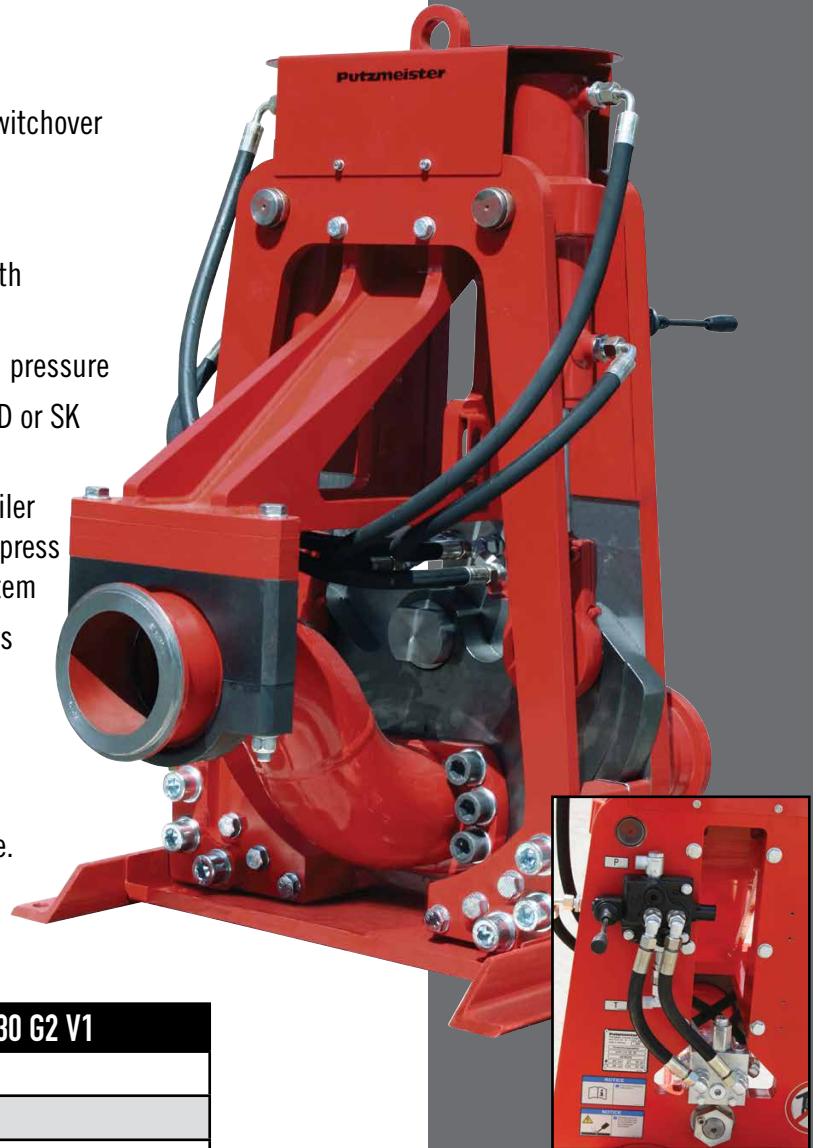

VALVE SPECIFICATIONS

Description	SDVH 3/2 125 130 G2 V1
Part Number	562143
Operation	Hydraulic
Max Delivery Pressure	1,885 psi (130 bar)*
Max Hydraulic Pressure	3,625 psi (250 bar)
Pipeline Diameter	5" (125mm)
Coupling	5.5" ZK
Ports/Positions	3/2
Weight (approx)	838 lbs (380kg)

*Standard delivery line system rated at max line pressure of 1,233 psi (85 bar)

Putzmeister Pipe Technology
1733 90th Street
Sturtevant, WI 53177 USA
Phone: (866) 734-0296
Fax: (866) 644-1527
PutzmeisterAmerica.com

